

Introduction

The purpose of this application note is to inform the system designer how to use the HI7190 with a single +5V analog supply if a -5V analog supply is not available. An inexpensive low current negative power supply can be generated with the ICL7660S voltage converter. The ICL7660S Voltage Converter is a monolithic CMOS voltage conversion IC. The device performs supply voltage conversion from positive to negative for an input range of 1.5V to 12V, resulting in complementary output voltages of -1.5V to -12V. Only 2 noncritical external capacitors are needed for the charge pump and charge reservoir functions. The conversion chip contains a series DC power supply regulator, RC oscillator, voltage level translator, and four output power MOS switches. For detailed chip information please refer to the ICL7660S datasheet.[1]

Functional Description

The HI7190 single supply circuit is shown in Figure 1. This includes a standard HI7190 application circuit, a ICL7660 voltage converter and two 10µF capacitors. The HI7190 data sheet [2] contains information on the application circuit, therefore, this discussion will focus on the voltage conversion circuit.

ICL7660 Theory of Operation [1]

The ICL7660S contains all the necessary circuitry to complete a negative voltage converter, with the exception of 2 external capacitors which may be inexpensive 10µF

polarized electrolytic types. The mode of operation of the device may be best understood by considering Figure 2, which shows an idealized negative voltage converter. Capacitor C₁ is charged to a voltage, V₊, for the half cycle when switches S₁ and S₃ are closed. (Note: Switches S₂ and S₄ are open during this half cycle.) During the second half cycle of operation, switches S₂ and S₄ are closed, with S₁ and S₃ open, thereby shifting capacitor C₁ to C₂ such that the voltage on C₂ is exactly V₊, assuming ideal switches and no load on C₂. The ICL7660S approaches this ideal situation more closely than existing non-mechanical circuits.

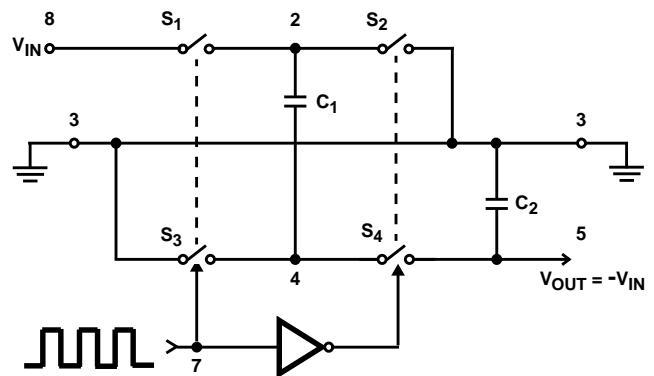

FIGURE 2. IDEALIZED NEGATIVE VOLTAGE CONVERTER

In the ICL7660S, the 4 switches of Figure 2 are MOS power switches; S₁ is a P-Channel devices and S₂, S₃ and S₄ are N-Channel devices. The main difficulty with this approach is that in integrating the switches, the substrates of S₃ and S₄

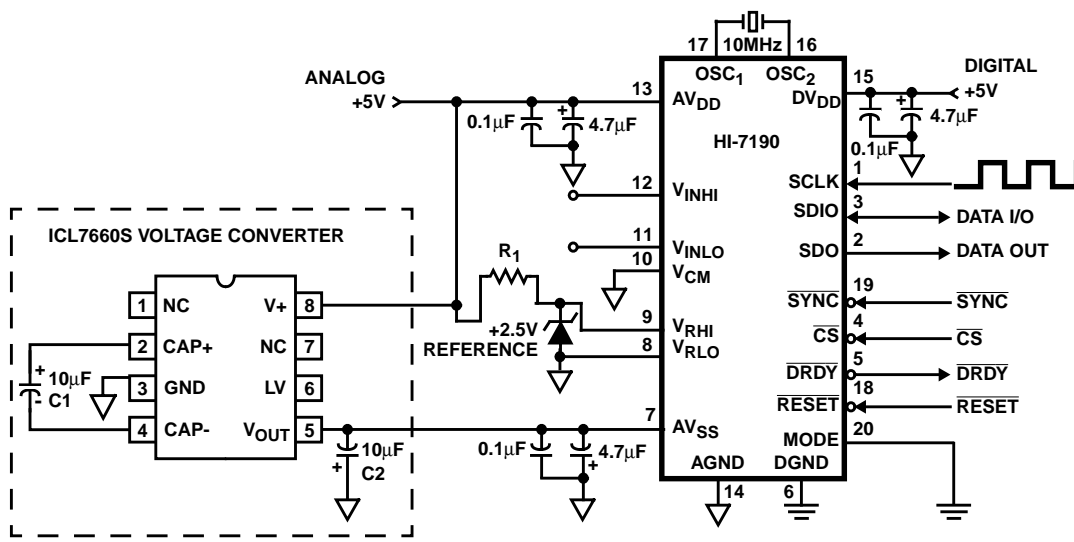

FIGURE 1A. VOLTAGE CONVERSION CIRCUIT

FIGURE 1. SINGLE SUPPLY APPLICATION CIRCUIT

must always remain reverse biased with respect to their sources, but not so much as to degrade their "ON" resistances. In addition, at circuit start up, and under output short circuit conditions ($V_{OUT} = V+$), the output voltage must be sensed and the substrate bias adjusted accordingly. Failure to accomplish this would result in high power losses and probable device latchup.

This problem is eliminated in the ICL7660S by a logic network which senses the output voltage (V_{OUT}) together with the level translators, and switches the substrates of S_3 and S_4 to the correct level to maintain necessary reverse bias.

The voltage regulator portion of the ICL7660S is an integral part of the anti-latchup circuitry, however its inherent voltage drop can degrade operation at low voltages. Therefore, to improve low voltage operation "LV" pin should be connected to GND, disabling the regulator. For supply voltages greater than 3.5V the LV terminal must be left open to insure latchup proof operation, and prevent device damage.

ICL7660 Application Discussion

The output characteristics of the voltage converter (Figure 1A) can be approximated by an ideal voltage source in series with a resistance as shown in Figure 3. The voltage source has a value of $-(V+)$ with a slight ripple voltage due to the ICL7660S switching between C_1 and C_2 . The output impedance (R_O) is a function of the ON resistance of the internal MOS switches (shown in Figure 2), switching frequency, the value of C_1 and C_2 , and the equivalent series resistance (ESR) of C_1 and C_2 .

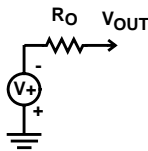

FIGURE 3. ICL7660S EQUIVALENT CIRCUIT

Below is an analysis of this application at 25°C. From the datasheet the MOS switch resistance is typically 23Ω, switching frequency is 10kHz. The capacitors C_1 and C_2 are 10μF, 16V Kemet Solid Tantalum capacitors type number "T350106K016AS" with ESR of 1Ω at 10kHz. The typical supply current into the HI7190 negative supply is 1mA. The low current requirement of the HI7190 is critical since the conversion chip is ONLY designed for low current applications. As defined in the ICL7660S datasheet, the inverted output voltage drops significantly from -5V to -4.25V when 10mA of current is required. If additional current is needed to drive supplementary devices, multiple ICL7660S

units can be placed in parallel [1]. Below are the theoretical calculations for output impedance and ripple voltage.

$$R_O \cong 2 \times R_{SW} + \frac{1}{0.5f_{OSC} \times C_1} + 4 \times ESR_{C_1} + ESR_{C_2} \Omega$$

$$R_O \cong 2 \times 23 + \frac{1}{(5 \times 10^3 \times 10 \times 10^{-6})} + 4 \times ESR_{C_1} + ESR_{C_2}$$

$$R_O \cong 46 + 20 + 5 \times 1 \Omega \cong 71 \Omega$$

$$V_{RIPPLE} \cong I_{OUT} \left(\frac{1}{2 \times f_{PUMP} \times C_2} + 2ESR_{C_2} \right)$$

$$V_{RIPPLE} \cong I_{OUT} \left(\frac{1}{2 \times 10kHz \times 10\mu F} + 2 \right)$$

$$V_{RIPPLE} \cong 7mV$$

Measured Performance

The circuit in figure 1A was added to the evaluation platform to determine performance. The testing consisted of both noise and linearity with the standard -5V supply and a -5V supply derived from the ICL7660S. Noise data was derived from 100 readings while linearity involved single measurements in 0.5 volt increments. Comparison of the performance data showed no degradation of either noise or linearity while using the ICL7660S voltage converter.

References

- [1] ICL7660S Datasheet, File Number 3179, Intersil Corporation, Melbourne, Florida, 1994.
- [2] HI7190 Datasheet, File Number 3612, Intersil Corporation, Melbourne, Florida, 1995.

All Intersil semiconductor products are manufactured, assembled and tested under **ISO9000** quality systems certification.

Intersil semiconductor products are sold by description only. Intersil Corporation reserves the right to make changes in circuit design and/or specifications at any time without notice. Accordingly, the reader is cautioned to verify that data sheets are current before placing orders. Information furnished by Intersil is believed to be accurate and reliable. However, no responsibility is assumed by Intersil or its subsidiaries for its use; nor for any infringements of patents or other rights of third parties which may result from its use. No license is granted by implication or otherwise under any patent or patent rights of Intersil or its subsidiaries.

For information regarding Intersil Corporation and its products, see web site <http://www.intersil.com>